

**USE:** use only on a Enduro-Freeride MTB fitted with disc brakes. Any other use (such as on a tandem, road bike, cyclo-cross bike, downhill bike...) is highly inadvisable, is the sole responsibility of the user and voids the Mavic warranty.



Recommended maximum weight of the cyclist and his equipment: 100 kg.

**WHEEL WEIGHTS WITHOUT QUICK-RELEASE SKEWER**

Front: 970 g  
Rear: 1085 g

**WHEEL REFERENCES**

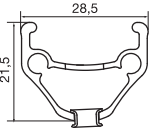
Front: 995 566 10  
Rear: 995 567 13  
Pair: 995 568 14

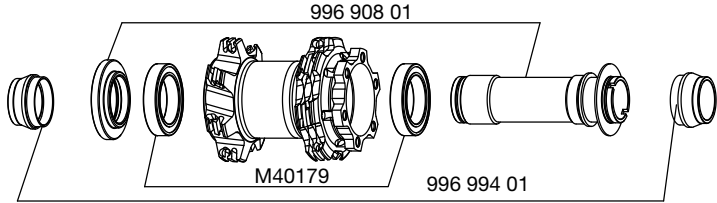
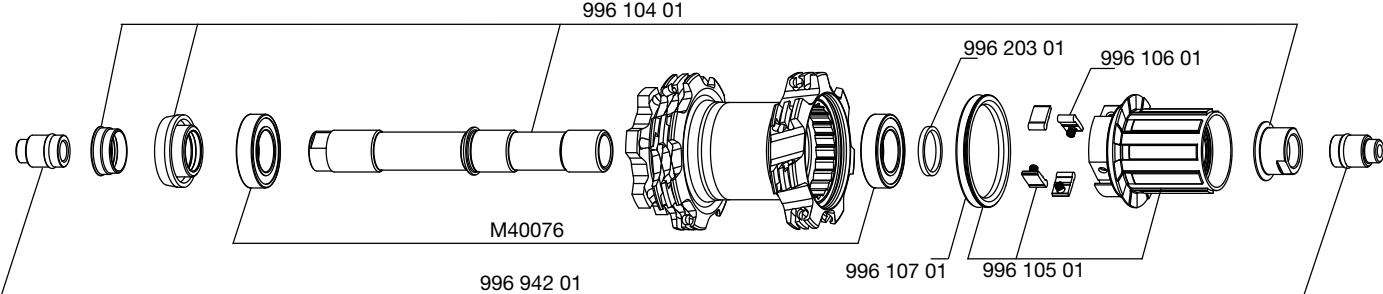
<b>RIMS</b>	<b>REFERENCES:</b> Front and rear: 996 902 15	
	<p><b>Ø VALVE HOLE</b></p>  <p>Ø: 8.5 mm Length.: ≥ 32 mm</p>	<p><b>RECOMMENDED TIRE WIDTH</b></p>  <p>Dimensions: Ø 26" ETRTO 559 x 21C compatible Recommended tire width: 2.1" to 2.5"</p>
<b>HUBS</b>	<b>MAINTENANCE:</b> Clean with a dry cloth or soap and water if necessary. Do not use a high-pressure washer.	
		
		
<b>WHEEL BUILDING</b>	<b>REFERENCES AND LENGTHS:</b> Front and rear: 996 903 01, length 273 mm, (per 14, with nipples)	
<b>FEATURES:</b> Black steel round straight pull spokes with Self Lock system and conventional spoke nipples.	<b>LACING PATTERN:</b> Front and rear: crossed 2 on both sides	<b>TENSION:</b> Front disc side: 110 to 130 kg Rear drive side: 110 to 130 kg
<b>ACCESSORIES</b>	<b>WHEELS SUPPLIED WITH:</b>	<b>MAINTENANCE</b>
<ul style="list-style-type: none"> <li>• BX 101 rear quick-release M40352</li> <li>• Fork support kit 20 mm 996 994 01</li> <li>• Axle reducers 12=&gt;9 mm 996 942 01</li> <li>• Rim tape</li> <li>• Free play bearing adjustment wrench M40123 (with rear wheel)</li> <li>• User guide</li> </ul>		<p>Replacing the front axle and bearings in the INT model See 2003 TM, page 18</p> <p>Rear wheel assembly diameter conversion See page 30</p> <p>Maintaining and replacing the free wheel mechanism See page 29</p> <p>Replacing the rear axle and bearings See page 30</p> <p>Replacing a spoke See 2004 TM, page 25</p> <p>Replacing the front rim See 2004 TM, page 28</p> <p>Replacing the rear rim See 2004 TM, page 29</p>
<p>To consult this information quickly in a practical manner, refer to <a href="http://www.tech-mavic.com">www.tech-mavic.com</a></p>		